



Dual-Polarized Variants of the Continuous Transverse Stub (CTS) Array

Originally invented at Hughes Aircraft Company in 1991, the Continuous Transverse Stub (CTS) array represents a new class of array antenna, exploiting the low-loss, low-dispersion, dimensional robustness, and design flexibility of an open parallel-plate structure as both its transmission-line and radiator basis. To date more than 30 different embodiments of this technology have been successfully demonstrated, including both electronically-scanned and dual-polarized implementations, at frequencies spanning from 5 through 94 GHz and over instantaneous operating bandwidths as large as a 4:1 ratio. Relative advantages of this array type include: unusually high aperture efficiencies and precision sidelobe control (through 94 GHz); benign active impedance dependence to both frequency and scan angles; and enhanced design robustness, simplicity, and low cost. As an additional benefit, the utilization of a simple parallel-plate cross-section as the basis for the transmission-line structure fully exploits the low dissipative loss, dimensional insensitivity, wide operating bandwidth, and low-dispersion typical of propagation within a parallel-plate structure. These favorable qualities contrast with the relative limitations of waveguide, microstrip, and strip-line transmission-line structures with respect to these attributes.

Specific variants of the basic Continuous Transverse Stub (CTS) array represent a proven and effective solution for achieving single- and multi-band, polarization-diverse capability in a single, high efficiency, low-profile, shared antenna aperture. These features are achieved by exploiting the unique “open” internal electromagnetic architecture of the basic (single-polarization) CTS array) through the distribution and subsequent radiation of two simultaneous orthogonal plane-wave excitations. In terms of its efficiency and performance as a radiator, the parallel-plate based radiating “stub” behaves (and models) similarly to a linear filamentary magnetic current source and therefore exhibits superior frequency-independent polarization purity (axial ratio) as compared to the band-limited (mode-limited) performance of slot-, patch-, and/or waveguide-based radiator alternatives.

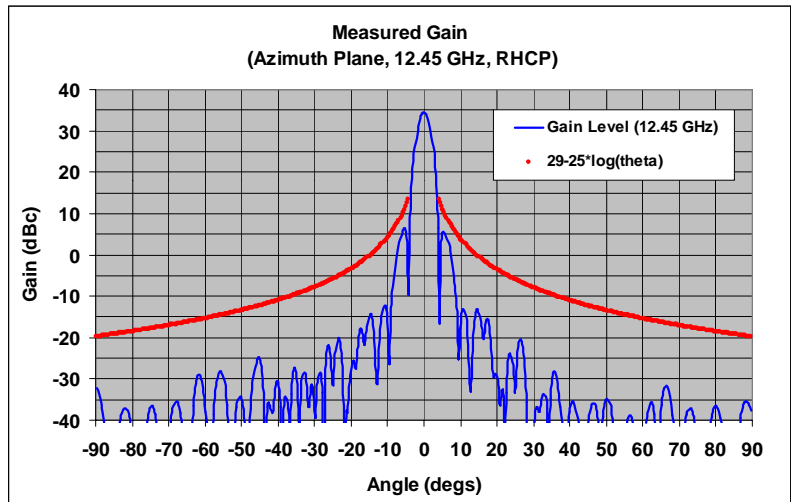

Figure 1. Dual-Polarized Ku-Band CTS Array **Figure 2. Measured Pattern for Dual-Polarized CTS Array**

Figure 1 illustrates a 19" x 19" x 1" dual-polarized CTS array, suitable for Direct Broadcast Satellite (DBS) reception over the 12.20 to 12.70 GHz frequency band and designed, developed, and successfully demonstrated in 1994. This antenna exhibited 1 dB greater G/T values, 10 dB lower sidelobes, and 50% less wind/roof-loading than the 18" parabolic dish it is designed to replace. A minimum polarization isolation of 25 dB (AR < 1.0 dB) was realized for both RHCP and LHCP with a total dissipative loss of less than 0.6 dB. This antenna is fabricated exclusively utilizing low-cost commercially-available materials (aluminum, low-density foam, and plastic) and processes (stamping, extruding, and injection molding), requiring no supplemental conductive bonding, brazing, gasketing, or interconnects of any kind. Recurring cost for this 19" x 19" antenna was estimated at \$40 per unit in 1994 and (with manufacturing innovations since that time) approximately \$25 in 2001. In addition, feed innovations over the past 7 years allow us to further enhance the efficiency (gain) thereby reducing its required size to 14" x 14." Figure 2 illustrates the measured Radiation Pattern Envelope (RPE) for this antenna (1994.)

For applications requiring simultaneous dual-polarized operation over very broad and/or multiple frequency bandwidths, the parallel-plate geometry of the CTS array may be further exploited to support this multi-functionality while preserving the simple low-cost attributes of its structure.



A CTS antenna exhibiting this broadband dual-polarization capability was successfully designed, fabricated, and demonstrated under funding from the Air-Force Research Laboratory (AFRL) in 1999.

Capable of supporting both the desired (extended) 17.7 to 21.2 GHz receive and 43.5 to 45.5 GHz transmit frequency bands simultaneously with dual-polarization (RHCP and LHCP) in both bands, this 3.2" x 3.2" x 0.65" aperture exhibited a minimum cross-polarization isolation of 22 dB (Axial Ratio < 1.4 dB) in a low-cost low-profile multi-layer form factor requiring no interconnects or RF critical joints. Figures 3 and 4 illustrate pictorially and schematically illustrate this dual-polarized/dual-band CTS aperture.



Figure 3. Dual-Polarized/Dual-Band CTS Array

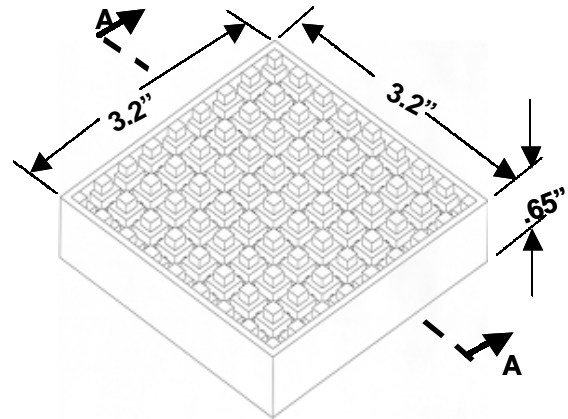

Figure 4. Isometric Subarray View

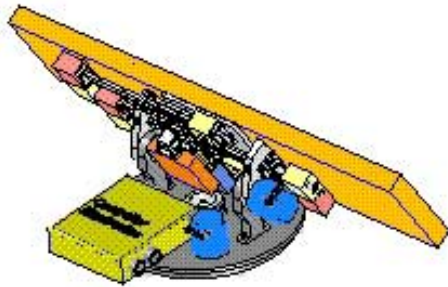

Figure 5. Dual-Polarized/Dual-Band CTS Array

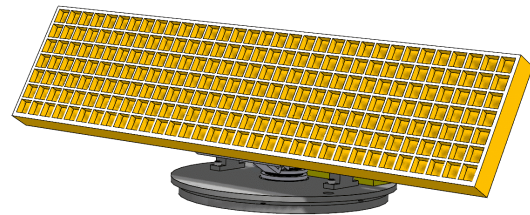

Figure 6. Isometric and Cross-Sectional Views

Current near-term applications of this technology include ground-based and airborne mobile SATCOM terminals.

Relative advantages of this innovative technology include:

1. **Superior Aesthetics and Enhanced Mounting Flexibility.** 25-60% smaller in area, 60-80% lower in wind-loading, and 60-90% smaller in volume than competing parabolic dish and printed planar array solutions.
2. **Superior Gain and Efficiency.** Unique low-loss Parallel-Plate transmission Line enables 90% minimum ohmic efficiency and 75% minimum overall efficiency over frequency bandwidth.
3. **Superior Polarization Control.** Unique filamentary magnetic current source nature of radiating line-sources provide suppressed frequency-independent cross-polarization isolation (axial ratio.)
4. **Superior Sidelobe Control.** Highly separable aperture distribution and unique phase and amplitude control provides for deep sidelobe suppression and steep radiation pattern envelopes with minimum taper loss (maximum efficiency.)
5. **Superior Value – Low-Cost Materials, Simple Fabrication and Assembly.** Minimum parts count comprised of plated-plastic and stamped metal parts with “press-fit” assembly and no critical RF joints.

For further information, please contact ThinKom Solutions, Incorporated at (310) 371-5486 or via email at BusDev@thin-kom.com.